



## Fiber-Insulated Heater Type FIH

### General Information

ZIRCAR Ceramics' Fiber-Insulated Heaters are combinations of high quality FeCrAl resistance wire and high purity ceramic fiber thermal insulation. Fiber-Insulated Heater Type FIH deliver fast, efficient and reliable uniform heat to temperatures of 1100°C (2012°F) with power densities up to 1500 watts/ft<sup>2</sup>. ZIRCAR Ceramics specializes in the design and manufacture of custom heaters for OEM furnace and thermal process equipment manufacturers as well as for end users with unique and demanding radiant heater requirements.

The lightweight ceramic fiber insulation built into FIH heaters is ZIRCAR Ceramics' Alumina-Silica Type AXL which exhibits very low thermal mass, low thermal conductivity and thus can handle extremely rapid cycling. FIH's coiled elements are typically locked into the insulation flush with the heated surface. This provides good support for the element and ensures long heater life. All ZIRCAR Ceramics' Fiber-Insulated Heaters are 100% organic free and will not smoke or outgas when heated.



### Characteristics & Properties

<p><b>Thermal Response:</b> FIH heaters are capable of very rapid heating. As process temperature is reached the very efficient thermal insulation works to minimize heat loss requiring less power to maintain temperature.</p>	
<p>The graph to the right shows Power (watts) plus Hot &amp; Cold Face Temperatures (°C) vs. time on a furnace composed of a cylindrical FIH, 6in.ID x 10in.OD x 6in.L, 1200W, 120V, with 2in. thick Alumina-Silica Type AXL discs on each end.</p>	

The data presented herein is intended to help the user in determining the appropriateness of this material for their application. This data is a nominal representation of this product's properties and characteristics and therefore should not be used in preparing specifications.

### ZIRCAR Ceramics, Inc.

PO Box 519  
100 N. Main St., Florida, NY 10921-0519  
Telephone: (845) 651-6600  
E-mail: sales@zircarceramics.com

Technical Data Bulletin  
Fiber-Insulated Heater Type FIH  
[www.zircarceramics.com](http://www.zircarceramics.com)  
Page 1 of 5

# Fiber-Insulated Heater Type FIH

## Availability of Standard Heaters

ITEM #	DESCRIPTION
CX15120A	FIH-C, 1in.ID x 3in.OD x 6in.L, 200w, 60V
CX15180A	FIH-C, 3in.ID x 6in.OD x 12in.L, 1200w, 120V
CX15270A	FIH-C, 8in.ID x 12in.OD x 12in.L, 3100w, 240V

## To Order

**Standard FIH:** order online or specify quantity, item # and description.

ZIRCAR Ceramics' Fiber-Insulated Heaters Type FIH are stocked in a few useful full cylinder configurations. Standard heaters listed above are available for immediate shipment from stock.

**Standard FIH Tolerances:** Unless otherwise specified, dimensional tolerances for FIH heaters are shown below.

**Standard FIH Resistance Tolerance:** Unless otherwise specified the resistance tolerance is generally +/-5%.

## Standard FIH Terminals:

Unless otherwise specified 9in. long, Type "A" uninsulated double twisted lead wires, are supplied as standard and positioned as indicated to the right.

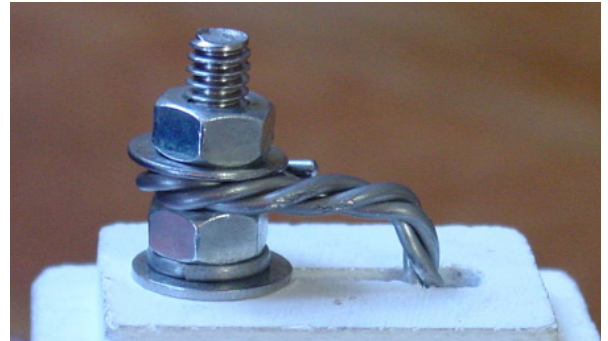
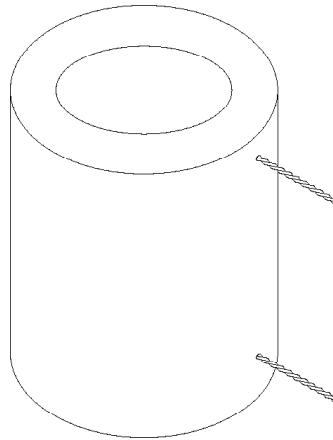

Double Twisted Leads are built into Standard FIH Heaters and can be wrapped around a terminal post, secured into a terminal block or terminated in high temperature crimped or welded connection.

## Custom FIH Terminals:

Numerous types and styles of terminations are available on FIH Heaters including solid and threaded rod, strip and flexible insulated leads.

**Custom FIH:** specify quantity and description by supplying drawings, sketches or written descriptions.

Custom FIHs are produced in numerous configurations including: flat panels, semi-cylinders, full round cylinders and other custom shapes. They are manufactured in single zone and multiple zone designs with a variety of lead styles and connecting hardware.

**Flat panel heaters** can be produced up to 36in. wide x 48in. long x 6in. thick. Custom heaters and shapes smaller than a few cubic inches and larger than several cubic feet can also be produced.

**Cylindrical heaters** can be produced with IDs from 1in. to 36in., with wall thicknesses from 1in. to 5in. in lengths up to 14in. Bonded assemblies of FIH Cylinders have been made in lengths up to 15 ft long.

**Staved cylinder heaters** typically produced have 24in. to 84in.ID, 1in. to 5in. wall thickness and segments up to 36in. long. Custom heaters and preparations are available on request. Our forming processes, large inventory of custom tooling and state of the art machining techniques allow a wide variety of sizes and shapes to be made. Special geometries such as disks, rings, custom bore (round corner square, hexagonal, oval, etc.) cylinders, staved cylinders, troughs, channel, angle, custom-machined shapes and others can be fabricated. Custom machining, compositional variations and the application of surface rigidizers and hardening agents are available.



## ZIRCAR Ceramics, Inc.

PO Box 519

100 N. Main St., Florida, NY 10921-0519

Telephone: (845) 651-6600

E-mail: [sales@zircarceramics.com](mailto:sales@zircarceramics.com)

[www.zircarceramics.com](http://www.zircarceramics.com)

## Fiber-Insulated Heater Type FIH

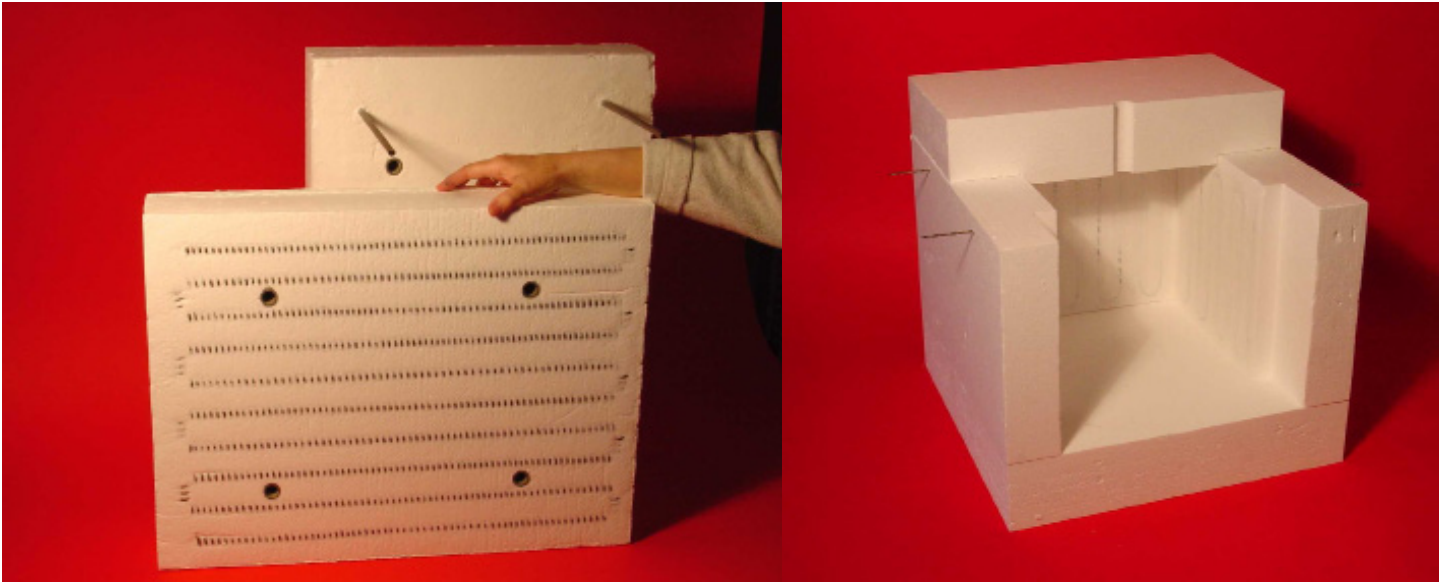

ZIRCAR Ceramics' FIH Heaters are custom designed and manufactured to serve both OEM and End User customers with unique and challenging heating and thermal process applications. Please contact ZIRCAR Ceramics to discuss your custom FIH Heater requirements.



**ZIRCAR Ceramics, Inc.**  
PO Box 519  
100 N. Main St., Florida, NY 10921-0519  
Telephone: (845) 651-6600  
E-mail: [sales@zircarceramics.com](mailto:sales@zircarceramics.com)  
[www.zircarceramics.com](http://www.zircarceramics.com)

## Fiber-Insulated Heater Type FIH

The figures below show a range of heater styles and lead locations.

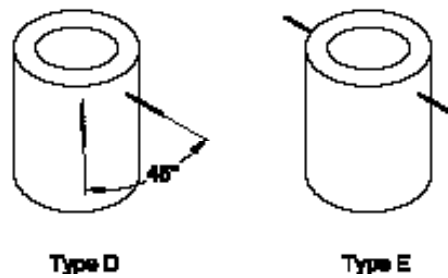
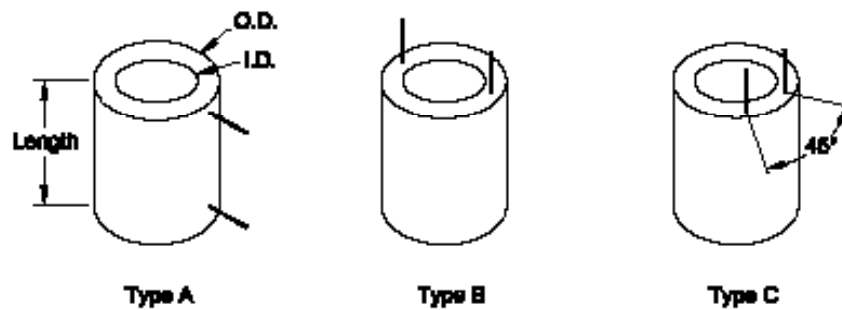
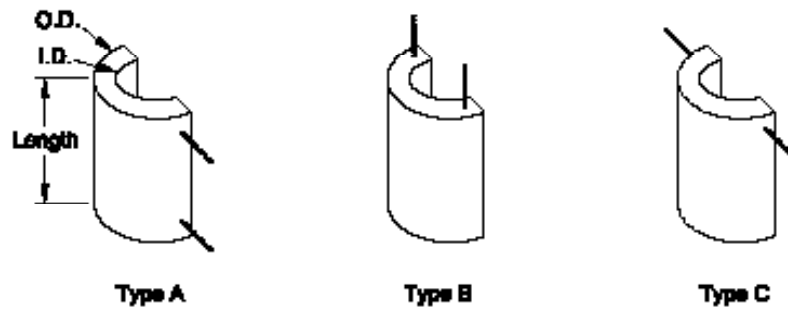
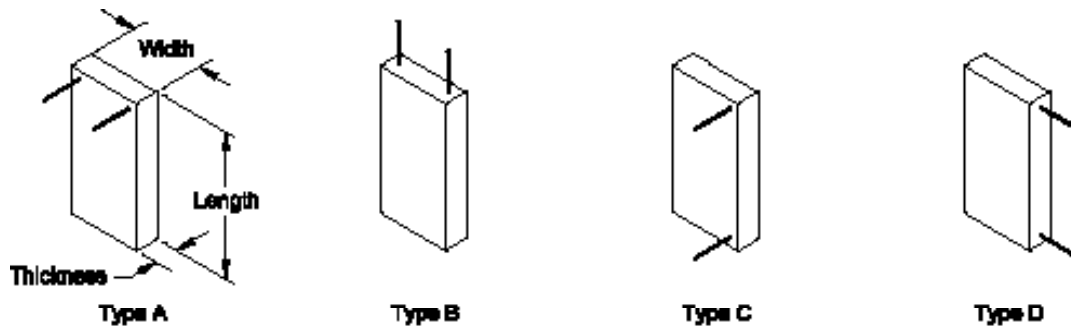

**ZIRCAR Ceramics, Inc.**  
 PO Box 519  
 100 N. Main St., Florida, NY 10921-0519  
 Telephone: (845) 651-6600  
 E-mail: [sales@zircarceramics.com](mailto:sales@zircarceramics.com)  
[www.zircarceramics.com](http://www.zircarceramics.com)

## Fiber-Insulated Heater Type FIH

**Tolerances:** This chart shows dimensional tolerances for FIH Heaters that are formed, demolded and dried only. Tighter tolerances are available with the use of drying fixtures or custom machining.

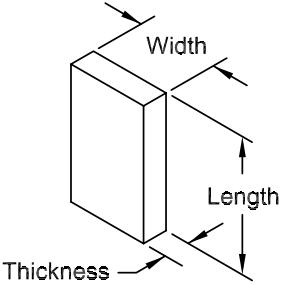
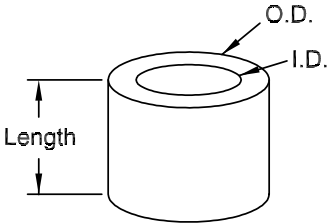
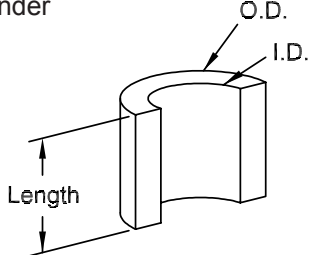
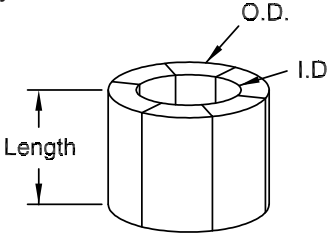
Flat Panels 	Length (in.)		Width (in.)		Thickness (in.)	
	+/- 1/4		+/- 1/4		1	2 to 6
Full Cylinders 	Inside Diameter (in.)		Outside Diameter (in.)		Length (in.)	
	3/4 to 4	5 to 30	3 & 3 1/2	5 to 40	6	12 to 36
	+/- 1/8	+/- 1/4	+/- 1/8	+/- 1/4	+/- 1/8	+/- 1/4
Semi-cylinder 	Inside Diameter (in.)		Outside Diameter (in.)		Length (in.)	
	1 to 3 1/2	5 to 18	+/- 1/4		6	12 to 36
	+/- 1/8	+/- 1/4			+/- 1/8	+/- 1/4
Staved Cylinder 	Inside Diameter (in.)		Outside Diameter (in.)		Length (in.)	
	+/- 1/4		+3/8/-1/4		+/- 1/4	



**ZIRCAR Ceramics, Inc.**

PO Box 519

100 N. Main St., Florida, NY 10921-0519

Telephone: (845) 651-6600

E-mail: [sales@zircarceramics.com](mailto:sales@zircarceramics.com)

[www.zircarceramics.com](http://www.zircarceramics.com)

Revision Date June 23, 2017